

Operation and Service Instructions

Micro-Abrasive Blasting Workstations

Issue Date: July 2016

This manual covers all variations of the Comco WS2200 and WS6000 series WorkStations (WS2200-1, WS2280-2, WS6000-2, etc.)

**Comco Inc.
2151 N. Lincoln Street
Burbank, California 91504
USA**

**Phone: 818-841-5500
www.comcoinc.com
E-mail: tech@comcoinc.com**

**Book P/N WS2019
File:WS Manual.doc**



Micro-Abrasive Blasting Workstations

Operation and Service

The Comco WS2200 and WS6000 series WorkStations are designed for use with all Comco series micro-abrasive blasters. Each workstation provides a generous work chamber illuminated by two fluorescent tubes. The work chamber has a large tempered glass viewing window that is hinged to facilitate loading and unloading of parts. Two 5" arm holes with flexible rubber iris baffles permit access so that an operator may hold work with one hand and a nozzle handpiece with the other. The workstation has a 4" dust exhaust connection at the rear so that a high capacity dust collection unit may be used to keep the abrasive dust completely controlled.

The Comco WS2200 and WS6000 WorkStations are designed to work as part of a micro-abrasive blasting system consisting of the following:

1. The workstation
2. Pressurized air (gas)
3. An air filter-dryer
4. A dust collection unit
5. A micro-abrasive blaster (AccuFlo[®], MicroBlaster[®], PowerFlo[®], or DirectFlo[™])

Micro-Abrasive Blaster

The micro-abrasive blaster is the heart of the blasting system. The manual that comes with your blaster will cover in detail the system requirements and operation. Refer to that manual for more information regarding preparation, set-up, operation and maintenance of your micro-abrasive blasting system.

Dust Collection Unit

An industrial type dust collector is necessary to provide adequate air flow to evacuate spent abrasive particles from the workstation. Typically the dust collector should be capable of providing 350 to 500 scfm of air flow through the workstation. If the dust collection unit delivers lower volumes of air, it will not be able to remove the heavier, coarser abrasives and will diminish the operator's visibility in the workstation.

The Comco Warranty

Comco warrants that the workstation will be free from all defects in material and workmanship under normal use for a period of one year from the date of purchase or 2,000 hours of normal operation, whichever comes first. Contact Comco Inc. for complete details and exclusions regarding this warranty.

Micro-Abrasive Blasting Workstations

Safety Precautions

The following safety precautions are essential for safe use of the workstation:

1. The workstation operates using high voltage electrical power. It has been designed to be safe to operate when used properly. Any device that uses electrical power requires that certain safety precautions be observed to avoid potentially hazardous situations.
 - Verify the proper operating voltage on the workstation by checking the nameplate located on the back of the unit.
 - Unplug the unit from facility power when removing the back panel, replacing lamps, or working near the lamp brackets.
 - Keep the interior of the workstation clean of dust, powder, and any foreign object or substance that could conduct electricity.
2. The workstation is typically used as part of a complete micro-abrasive blasting system. A dust collector **must** be used in conjunction with the workstation.
 - **Always** use a vigorous dust extraction device to prevent hanging dust clouds and minimize the risk of sparks from static electricity.
 - Flammable powders, such as wheat starch, walnut shell and plastic, may pose a fire or explosion hazard.
 - Some powders, if allowed to collect inside the machine, may cause electrical shorts.
 - If sensitive to powder or dust on the skin, wear gloves in the workstation.

Workstation Set-Up and Operation

Installation

1. Remove the workstation from its shipping container and place it securely on a solid workbench or counter so that the unit cannot tilt or fall over. Make sure that the location where it is to be used is within reach of a power outlet.

CAUTION: The workstation weighs approximately 45 to 55 pounds, depending on the model. Use appropriate caution while lifting.

2. Place the micro-abrasive blaster on or near the workstation according to the instructions in the blaster manual.
3. Identify the abrasive tubing leading from the vent pinch on the rear (or side) of the micro-abrasive blaster (see machine manual). Push the hose (or hoses) into one of the tubing grips on the back of the workstation. Push 1 to 2 inches of the tubing through the grip and hand tighten nut to secure tubing.

CAUTION: Failure to secure the free end of the vent hose may allow it to fall out of the workstation and potentially whip around if left unsecured. **Always** secure the free end of the hose.

Micro-Abrasive Blasting Workstations

4. Using a 4" diameter flexible duct and 2 hose clamps (usually provided with the dust collector), connect the workstation to a dust collection unit.
5. Follow the instructions in your micro-abrasive blaster manual to prepare for blasting.

CAUTION: The air that comes out of the nozzle contains abrasive. Do not point the nozzle at anything that could be harmed or damaged as a result of abrasive flow.

6. With the Power switch on the rear of the workstation turned to OFF, connect the power cord to the AC voltage outlet.
7. Turn the Power switch to the ON position. The lamps in the workstation should light.

Operation

1. Micro-abrasive blasting operations should be conducted according to the instructions in the blaster's operation manual.

CAUTION: Never point the nozzle in the direction of the glass window. The abrasive stream will etch the glass, reducing operator visibility and requiring premature replacement of the workstation window.

2. Turn the Power OFF when the workstation is not in use.

Common Problems, Causes and Solutions

Light won't illuminate

- | | |
|--|---|
| • Fluorescent lamps burned out | <ol style="list-style-type: none">1. Remove old lamps2. Replace lamps (commercial items) |
| • Powder build-up in lamp bracket, preventing electrical contact | <ol style="list-style-type: none">1. Unplug unit2. Remove lamps3. Use brush to clean out bracket4. Reinstall lamps5. Plug in unit and test |
| • Ballast failed | <ol style="list-style-type: none">1. Remove lamps2. Turn Power switch to ON3. Using voltmeter, test for voltage across lamp bracket terminals <p>CAUTION: Practice electrical safety to prevent shock.</p> |
| • Switch failed | <ol style="list-style-type: none">1. Unplug unit2. Remove back panel3. Using ohmmeter, test for continuity across switch terminals with the switch set to ON. |

Dust builds up inside

Service dust collector

Comco Workstations – Wiring Diagrams

WS2200 Series Classic WorkStation – 115 or 230V WS6000 Series ClearView WorkStation – 115 or 230V

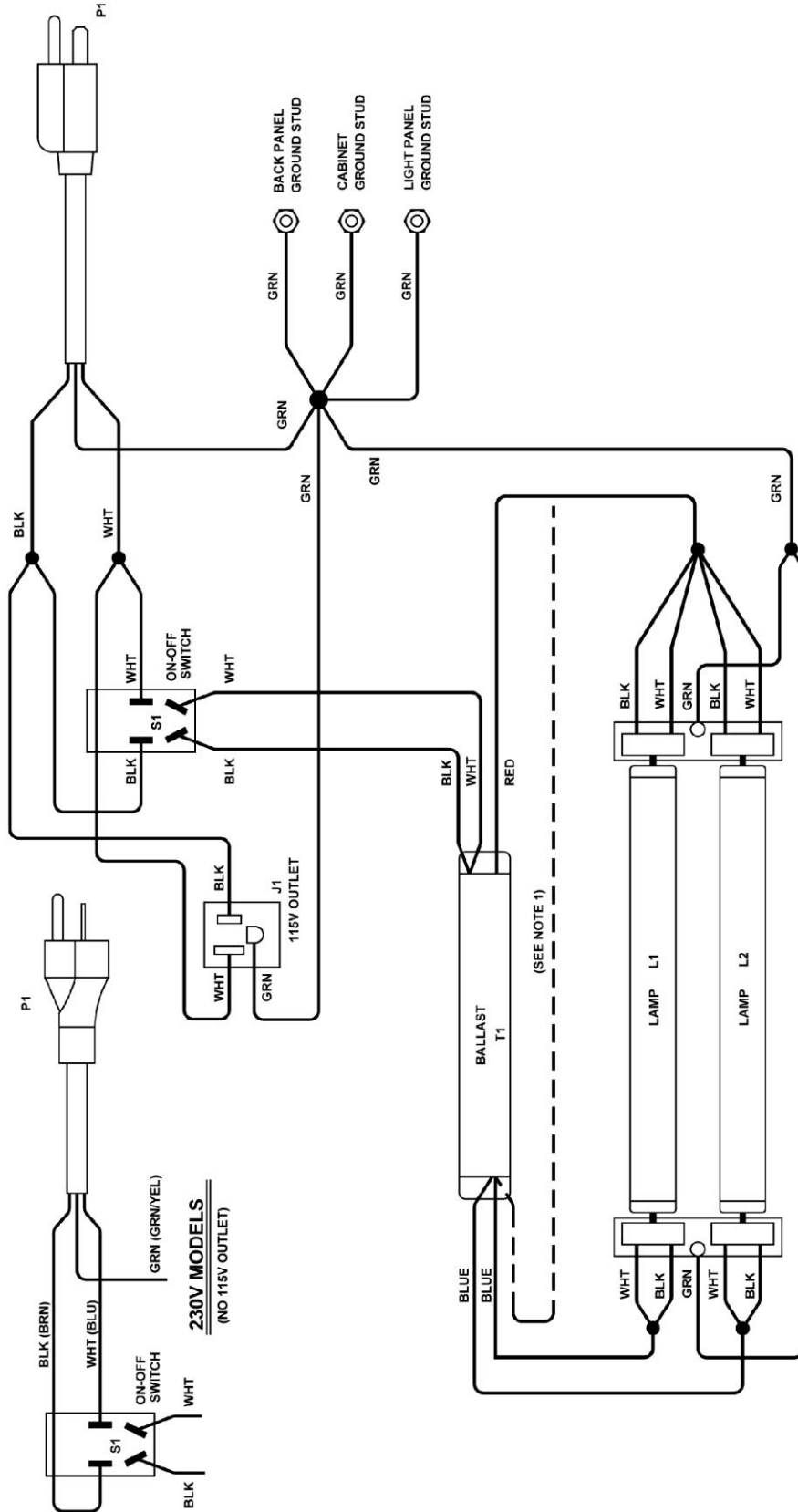

NOTES:
1. RED WIRE MAY EXIT BALLAST FROM EITHER END.

WS2200 Classic WorkStation

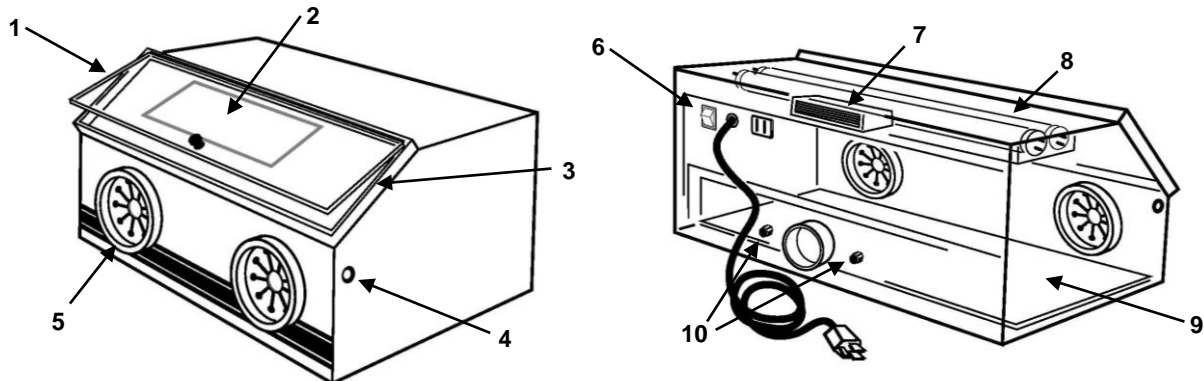

WS6000 ClearView WorkStation

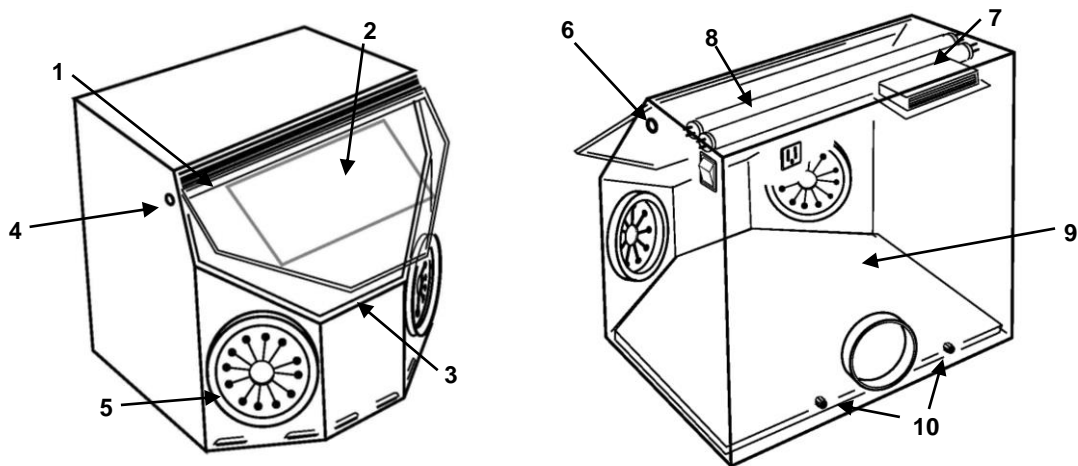

Item	Description	WS2200 Classic	WS2280 Big Box	WS6000 ClearView
1	Window Assembly	WS2014-2	WS2014-2	WS6014
	Window (Glass only)	WS1138-2	WS1138-2	N/A
2	Window Shield	WS2279-3 (3-pack) WS2279-10 (10-pack)	WS2279-3 (3-pack) WS2279-10 (10-pack)	WS2279-3 (3-pack) WS2279-10 (10-pack)
3	Seal	ST3260	ST3260	ST3366
4	Grommet ⁽¹⁾	ST5311-2	ST5311-2	ST5311-2
5	Iris, 5" ⁽²⁾	WS6006	WS6006	WS6006
6	Switch	ST7003	ST7003	ST7977
7	Ballast, 115/230V	ST7997-1	ST7997-1	ST7997-1
8	Lamp ⁽³⁾	ST7164	ST7164-3	ST7164-4
9	Mat	WS1136	WS2255-2	WS6007
10	Tube Grip, Bulkhead ⁽⁴⁾	ST5640-3	ST5640-3	ST5640-3

- 1) Workstations with 5/8" dia. holes in panels use Grommet P/N ST5311
- 2) Older workstations (S/N below 4460) use 4" Iris P/N WS2028-1
- 3) Standard replacement lamps are available at most hardware stores.

Comco Part No.	ST7164	ST7164-3	ST7164-4
Lamp Type	F15T8	F20T8	F14T8

- 4) Workstations with 3/8" holes in the rear panels use Grommet P/N ST5010.